

SWS-200/250-51K Supplemental Water System

Rotisserie Ovens, Combi-Steam Ovens and similar cooking devices are becoming more popular in commercial kitchen applications. The effluent that drains from these ovens consists of heavy fat concentration. The piping from these ovens quickly clogs with grease. A Big Dipper® unit can solve this problem.

Another issue faced with this type of installation is that there is no ready water supply to keep the static water level of the grease interceptor at a normal level. As the skimming wheel removes the grease, there is no sink draining into the unit to replenish the displaced grease and oils.

To address both of these issues, Big Dipper is designed with a **SWS-200/250-51K Supplemental Water Supply System** to be used in conjunction with a Big Dipper W-200-IS and W-250-IS Point Source Grease Removal Units. The SWS-200/250-51K allows the Big Dipper unit to be installed directly to the Oven, while the water replenishment system supplies a flow of water to replace the removed grease. This allows the static water level inside the Big Dipper to remain at a normal level.

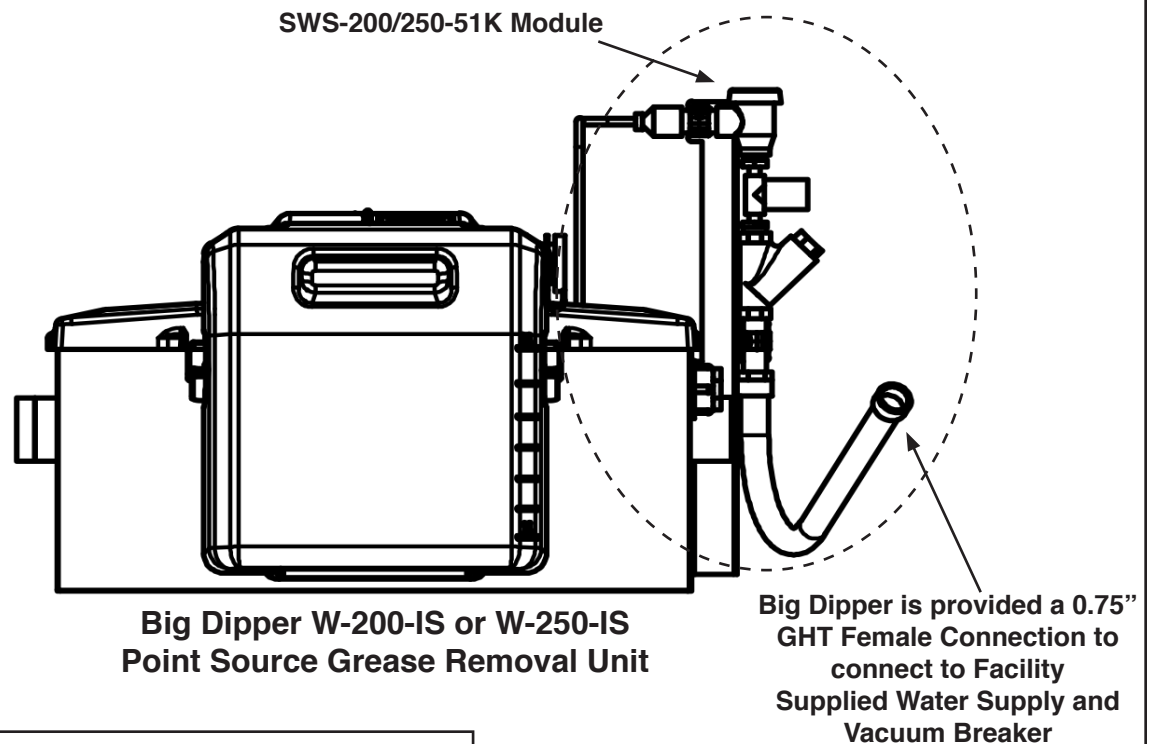

Electrical Requirements*:

120V, 50/60 Hz, 20 W, 0.5 Amps

Water Requirements (Supplied by Facility):

5 Gallons per Hour, 40 - 70 PSI

* A 230V, 50/60 Hz SWS-200/250-51K is also available.

SWS-200/250-51K Supplemental Water System

SWS-200/250-51K Side View
Coupled with Big Dipper W-200-IS Unit

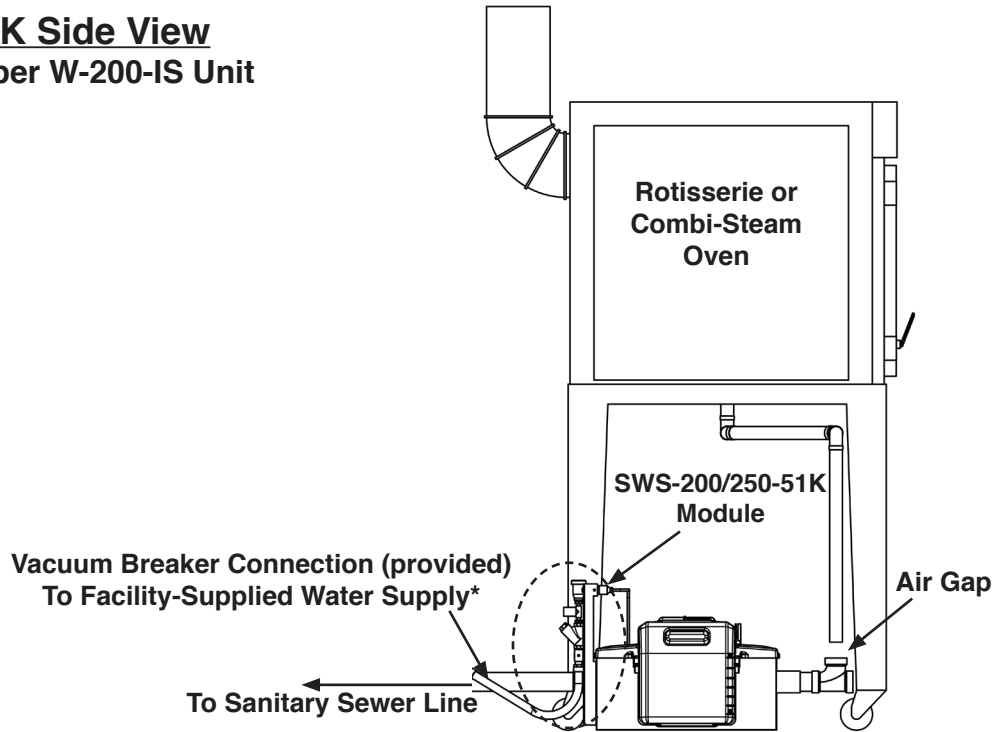

*Big Dipper is provided with a 0.75" GHT Female Connection to connect to Facility Supplied Water Supply

SWS-200/250-51K Front View
Coupled with Big Dipper W-200-IS Unit

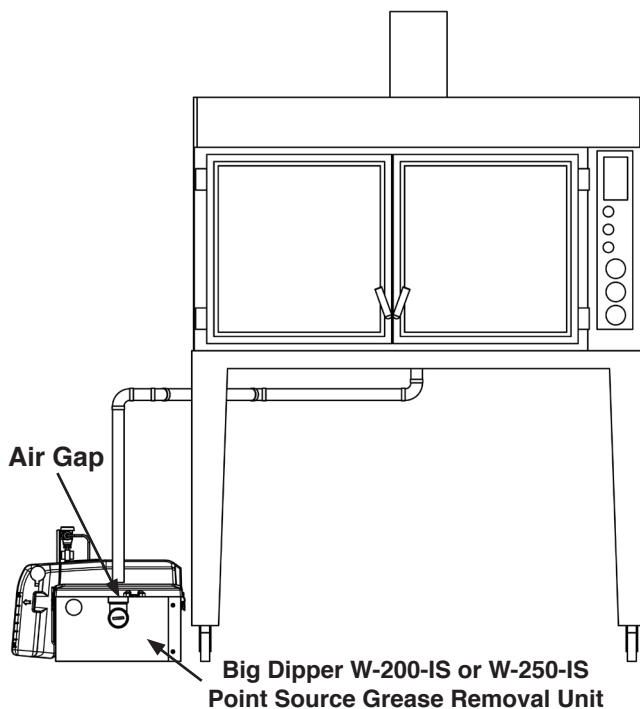

Ovens on Wheels may be moved for optimum position over the Air Gap

NOTE: Drawing for reference only. Equipment must be installed in compliance with all applicable laws, regulations and codes, including plumbing codes. Installation should be performed by a qualified plumber.