

BIG DIPPER[®]

A THERMACO[®] Technology

GUIDE

Installation Guideline



4 factors for a Big Dipper installation:

(1) Location of unit, (2) Inlet piping, (3) Vessel vent, & (4) Outlet vent.



(1) **LOCATION:** Install the Big Dipper as close as possible to the fixture(s) it is serving. The unit should be visible and easily accessible for daily maintenance and inspection. Do not install a Big Dipper in a vault.

(2) INLET PIPING:

Straight plumb into the Big Dipper unit. The unit has an internal gas trap and does not require a p-trap, unless required by your local code.

(3) VESSEL VENT

Purpose: Regulate tank pressure

The vessel vent connection can be found on the outlet side of the tank. Connect the vessel vent to the facility vent.

(4) OUTLET VENT

Purpose: Prevent siphonage

Vent to: facility vent or code-approved vacuum breaker (at least half the diameter of outlet pipe). Failure to properly vent outlet voids Thermaco's warranty.

Installation Diagram:

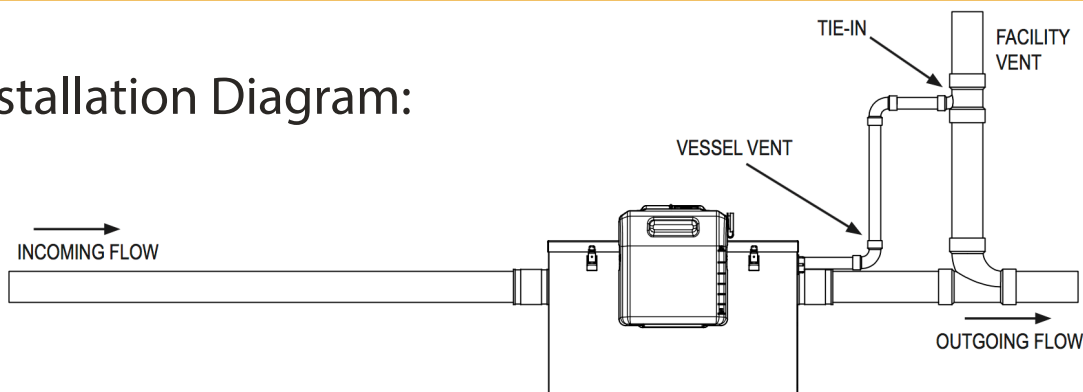

This guide provides an overview of optimal product installation practices. Refer to the manual for more installation options and detailed instructions. Equipment must be installed in compliance with all applicable laws, regulations and codes, including plumbing codes. Installation should be performed by a qualified plumber.