

PRODUCT FEATURES

- Fully automatic self cleaning cycle. Removes collected grease & oils from tank without any operator assistance. Comes complete with Digital Control user interface and Grease Collector.
- Constructed of corrosion resistant materials suitable for installation in virtually any location. Attractive sanitary Stainless Steel exterior.
- Integrated Motor/Grease Outlet/Heater/Lid enables a fast, do-it-yourself unit operation reversal.
- Patent Pending Advanced Odor Protection design locks in odors from grease and solids.
- Compact footprint.
- Two (2) No-Hub Connectors provided.

SPECIFICATIONS

Construction: _____ Exterior: 304 Stainless Steel, Bright Finish
Injection Molded Polymer
Interior: Rotationally Molding Polyethylene

Electrical: _____ 115 VAC, 50/60 Hz, 1173 Watts (10.2 Amps)*
Electrical Cord Length: _____ 8 feet

Flow Rating: _____ 50 GPM (3.15 l/s)

No. of Skimming Wheels: _____ 1

Skimming Rate: _____ 9 Pounds (4.08 Kg) Per Hour

Grease Retention Capacity: _____ 108.4 Pounds (49.2 Kg)

Internal Solids Strainer Capacity: _____ 2.5 Gallons (9.5 Liters)

Inlet/Outlet: _____ 3" (76 mm)

Product Weight: _____ 70 lbs (31.8 Kg)

*For Additional Electrical Configurations, see Electrical Variations section on page 2.

END VIEW

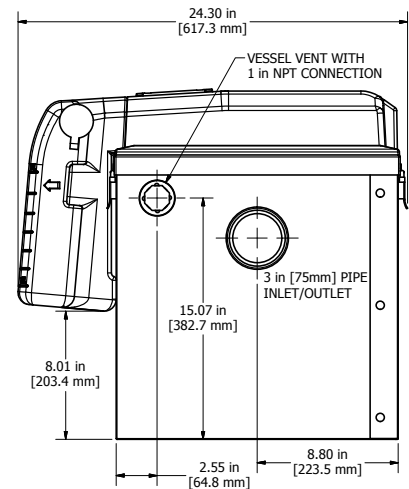

SIDE VIEW

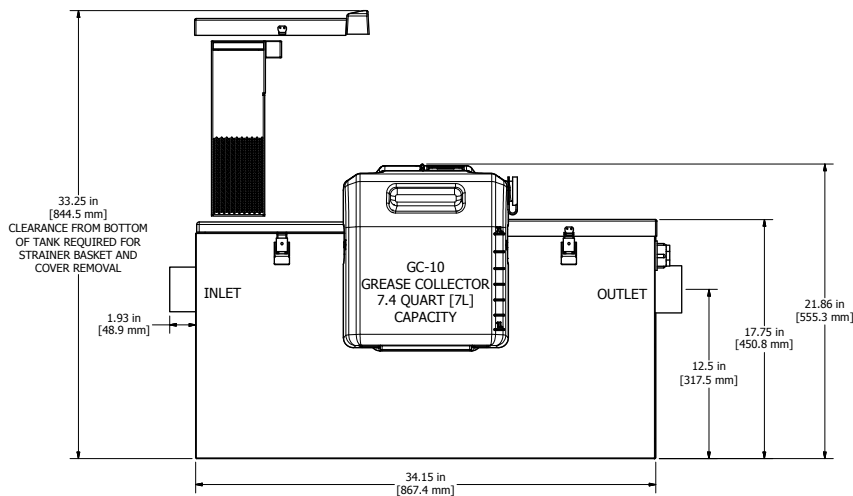

TOP VIEW

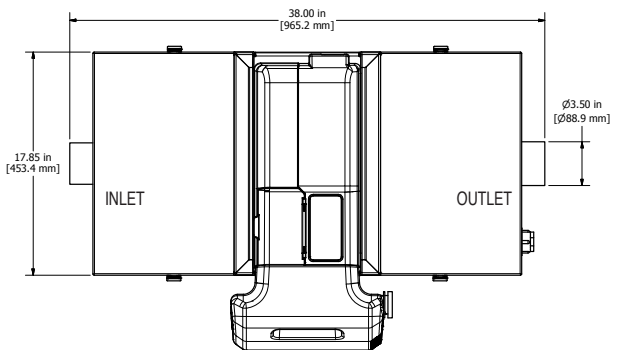

Conforms to ASME Standard ASME A112.14.3 and A112.14.4



INSTALLATION NOTES

1. READ instruction manual included with system before installing/operating.
2. Install unit allowing for the minimum clearances shown. Make sure there is sufficient space above Internal Strainer access cover to remove the strainer [minimum of 15.5" (394mm)]
3. Make piping connections with rubber "No Hub" connectors.
4. Keep outlet piping as straight as possible. Use only "sweep" connections.
5. Install vent on outlet piping.
6. Fill the tank with water before energizing the power to the motor and heater.
7. Do not install "P" Trap on outlet connection of tank (unit already has internal gas trap).
8. Do not reduce pipe size on outlet piping
9. Do not pressure test unit.

Equipment must be installed in compliance with all applicable laws, regulations and codes, including plumbing codes. Installation should be performed by a qualified plumbing contractor.

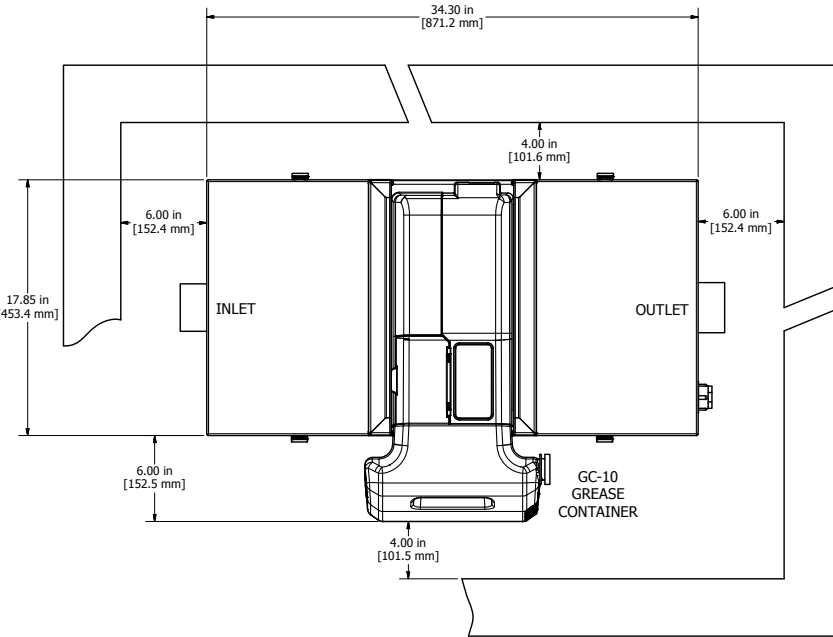

JOB SPECIFICATION

Grease and oils separator(s) shall be Thermaco Big Dipper automatic grease/oil recovery system(s) as manufactured by Thermaco, Inc., Asheboro, North Carolina as noted on plans.

AUTOMATIC GREASE REMOVAL DEVICE SPECIFICATIONS

Furnish and install ___ Thermaco Big Dipper Model No. W-500-IS, bright finish type 304 stainless steel exterior, rotationally molded polyethylene interior automatic self-cleaning grease and oil recovery separator(s) for floor mounted or partially recessed installation, rated to ASME A112.14.3 and/or PDI-G 101 standards at 50 gallons per minute (3.15 l/s) peak flow, 108 pounds (49.2 Kg) of grease capacity and including as an integral part of the unit, 3" (75 mm) inlet/outlet, 1 rotating gear oleophilic/hydrophobic skimming wheel assembly for automatic grease/oil removal, flow control device, self-regulating electric immersion heater with thermostatic control, 1" (25mm) vessel vent, integral gas trap, digital control for programmable operation, field reversible motor assembly and grease/oil sump outlet, quick release stainless steel lid clamps, fully removable integral polymer/304 grade stainless steel lid with magnetic lid tensioners, internal stainless steel strainer basket for collection of coarse solids, polymer wiper blade unit and a separate gasketed removable grease and oils collection container with carry handle and pouring spout. Electric assembly shall be tested to comply with pertinent sections of the Standards for Safety ANSI/UL 73 and/or ANSI/UL 1004. Electric motor equipped with overload protection. Two (2) no-hub connectors for plumbing connection provided.

ELECTRICAL VARIATIONS

- W-500-IS: 115V 50/60Hz, 1173 Watts (10.2 Amps)
- W-500-IS-E: 230V 50/60Hz, 1173 Watts (5.1 Amps)

SUBMITTAL OPTIONS

- CF-VENT-1 Carbon Vent Filter
- HAG-3 Horizontal Air Gap Assembly with 3" connection (comes with 3 flow restrictors for sink drains)
- HAG-BA-1 Solids Strainer Baskets for use with HAG-3 Assembly (Specify Quantity based on Number of Sinks: ___)
- SFK-2 Support Frame Kit, stainless steel construction