

**Material: Rotationally Molded Polyethylene**

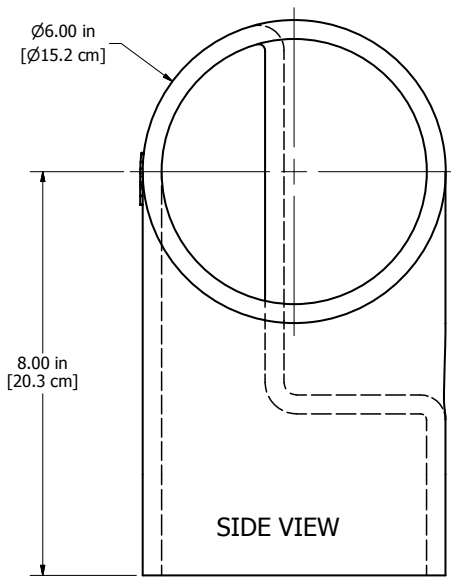

The **MFSH-66 Horizontal Flow Splitter Module** splits a single effluent flow exiting a kitchen into two separate, equal flows in large institutional-type installations or for sites that need central grease removal but have a small footprint. The kitchen flows are diverted into twin Trapzilla Units installed horizontally beside one another. For example, couple two TZ-1826-6 (100 GPM) units together to pretreat a single 200 GPM flow from a kitchen. The MFSH-44 has a 6" Inlet Coupling and splits off into two 6" Outlet Couplings.