

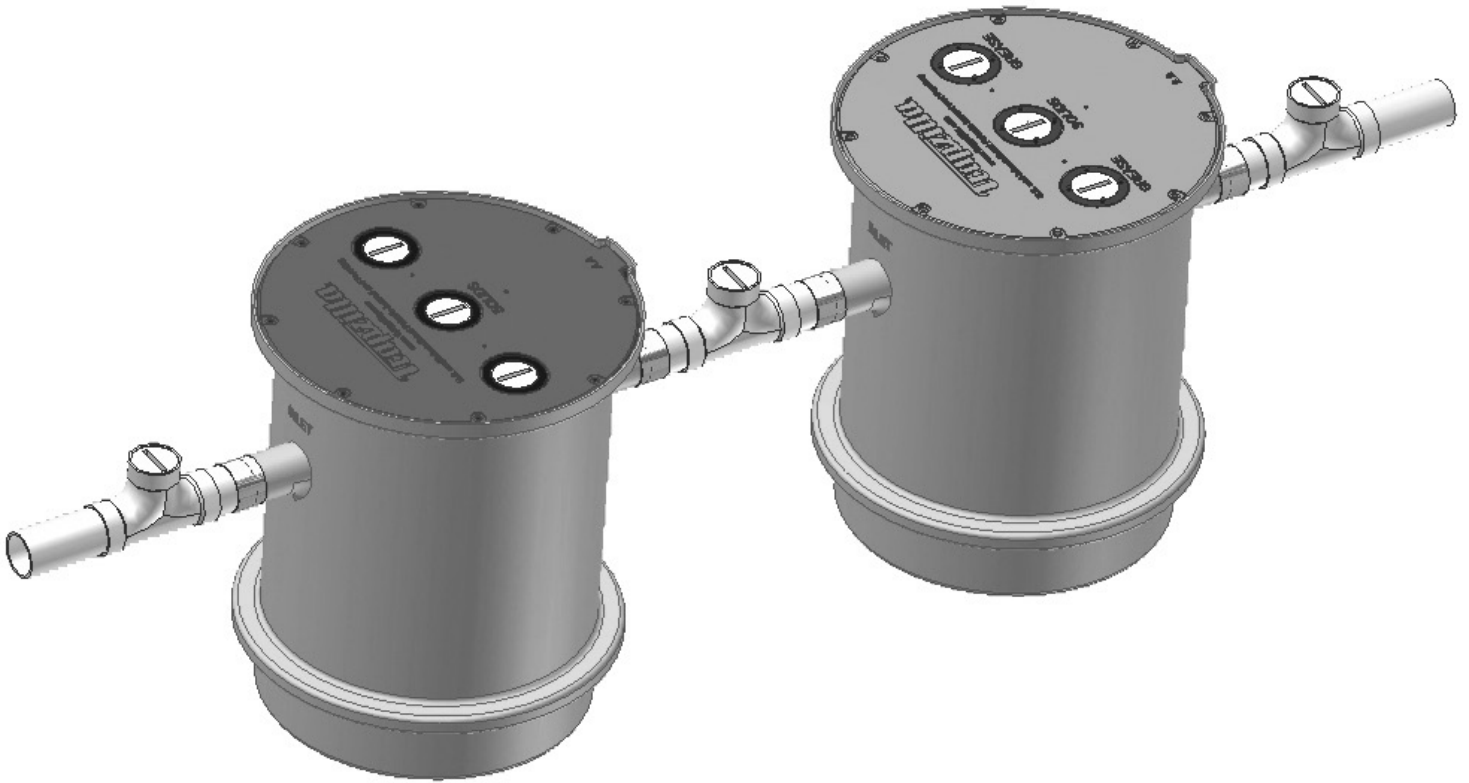

Installation & Maintenance Instructions For Trapzilla® Solids Separators



**TSS Trapzilla Solids
Separators**

Copyright ©2008 Trapzilla® Thermaco, Inc. • P.O.Box 2548 • Asheboro, NC 27204
Toll Free: (800) 633-4204 • V: (336) 629-4651 • F: (336) 626-5739
E-mail: info@thermaco.com • Online: www.big-dipper.com



Table of Contents

System Overview3

Plumbing Installation4

System Maintenance6

Options8

Limited Warranty13



Trapzilla® Solids Separators

System Overview

Trapzilla® System Overview

The **Thermaco, Inc. Trapzilla®** Supercapacity Grease Trap collects free-floating grease & oils contained in kitchen drain water flows. As most food service facility managers already know, grease buildup inside a building's grease containment system is a major cause of problems due to exterior drain line blockages. These problems jeopardize normal operations as well as create health and safety hazards within the facility itself.

Thermaco, Inc. also offers the **TSS Trapzilla Solids Separator** that traps incidental kitchen solids upstream of the Trapzilla Grease Interceptor.

The proper installation of a Trapzilla® Supercapacity Solids Separators can reduce or eliminate solids problems and costly sewer surcharges and fines through efficient separation and retention of incidental solids.

The unique compact design of the Trapzilla allows for installation into most facilities. Options are available that enable a Trapzilla unit to be installed on the floor, suspended from the ceiling or in-ground outside the facility.

Trapzilla Solids Interceptor units are designed to treat high flows of kitchen drainwater with large solids storage capacity within a small footprint unit. These units are easy to maneuver into position and just as easy to plumb.

Grease interceptors, grease traps, automatic recovery units, grease removal devices, solids separators and other similar plumbing devices receiving kitchen flows from sinks, floor drains, woks and other food bearing sources may generate odors. There are many factors influencing odor evolution and dissemination. These include room ventilation, kitchen menu, ambient temperatures, ware washing practices, grease/oil input, daily input fluid volume, sanitizers, installation plumbing design and product maintenance/upkeep. Odors are usually prevented by good area ventilation, frequent fluid inputs, good product maintenance practices and proper product installation. Additional steps, including aeration, chlorination, improved area ventilation and additional maintenance control, may be needed at some sites.

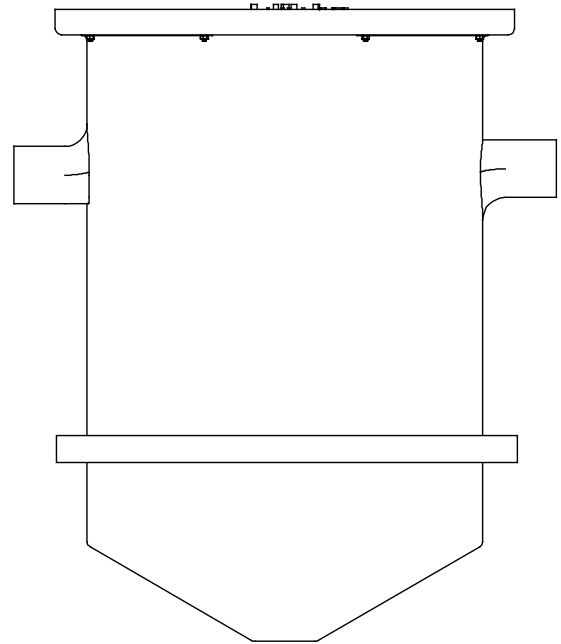



Trapzilla® Solids Separators

Plumbing Installation

Trapzilla® Plumbing Installation

Locating the Unit

The system should be visible and easily accessible for maintenance and inspection. Options are available to install the Trapzilla in a basement, suspended from a ceiling or in-ground in an exterior location. Make sure that adequate room is provided around the unit to allow easy access for a pump truck operator. Make sure the height above the Trapzilla access cover is enough to properly service the system.

Inlet/Outlet Piping

The inlet and outlet piping connections require flexible sleeve pipe couplings. Keep outlet piping as straight as possible. Thermaco, Inc. recommends installation of 4" (100 mm) Two-Way Cleanouts on both the Inlet and Outlet of the Trapzilla® unit in accordance with all applicable laws, regulations and codes. Use only "sweep" connections. Do not reduce the pipe sizing on the outlet piping. Do not install "P" trap on outlet connection of system.

Venting the Outlet

An outlet vent or approved vacuum breaker of at least 1/2 the diameter of the system's outlet connection must be present as close as possible to the Trapzilla outlet to prevent possible siphonage problems. The Vent on the Outlet piping is to be installed in accordance with all applicable laws, regulations and codes. Failure to provide a vent for the system voids Thermaco's Limited Warranty for the system.

For High Head Height Applications Over Six (6) Feet (1.95 m)

For installations where there is head height of greater than 6 feet (1.95 meters), Thermaco, Inc. recommends installation of a code-approved Vented Flow Control.

Do Not Use With Food Grinders, Potato Peelers or Waste Disposal Units

Installations where the system is connected to a Waste Disposal Unit, Garbage Grinder or potato peeler will void Thermaco's Limited Warranty for the system.

**Note: Drawing for reference only.
Equipment must be installed in compliance with all applicable laws, regulations and codes, including plumbing codes. Installation should be performed by a qualified plumber.**



Trapzilla® Solids Separators

Plumbing Installation

Trapzilla® Plumbing Installation

Thermaco, Inc. recommends installation of 4" (100 mm) Two-Way Cleanouts on both the Inlet and Outlet of Trapzilla® Models TSS-70 and TSS-95 in accordance with all applicable laws, regulations and codes. A Vent on the Outlet piping is also to be installed in accordance with all applicable laws, regulations and codes.

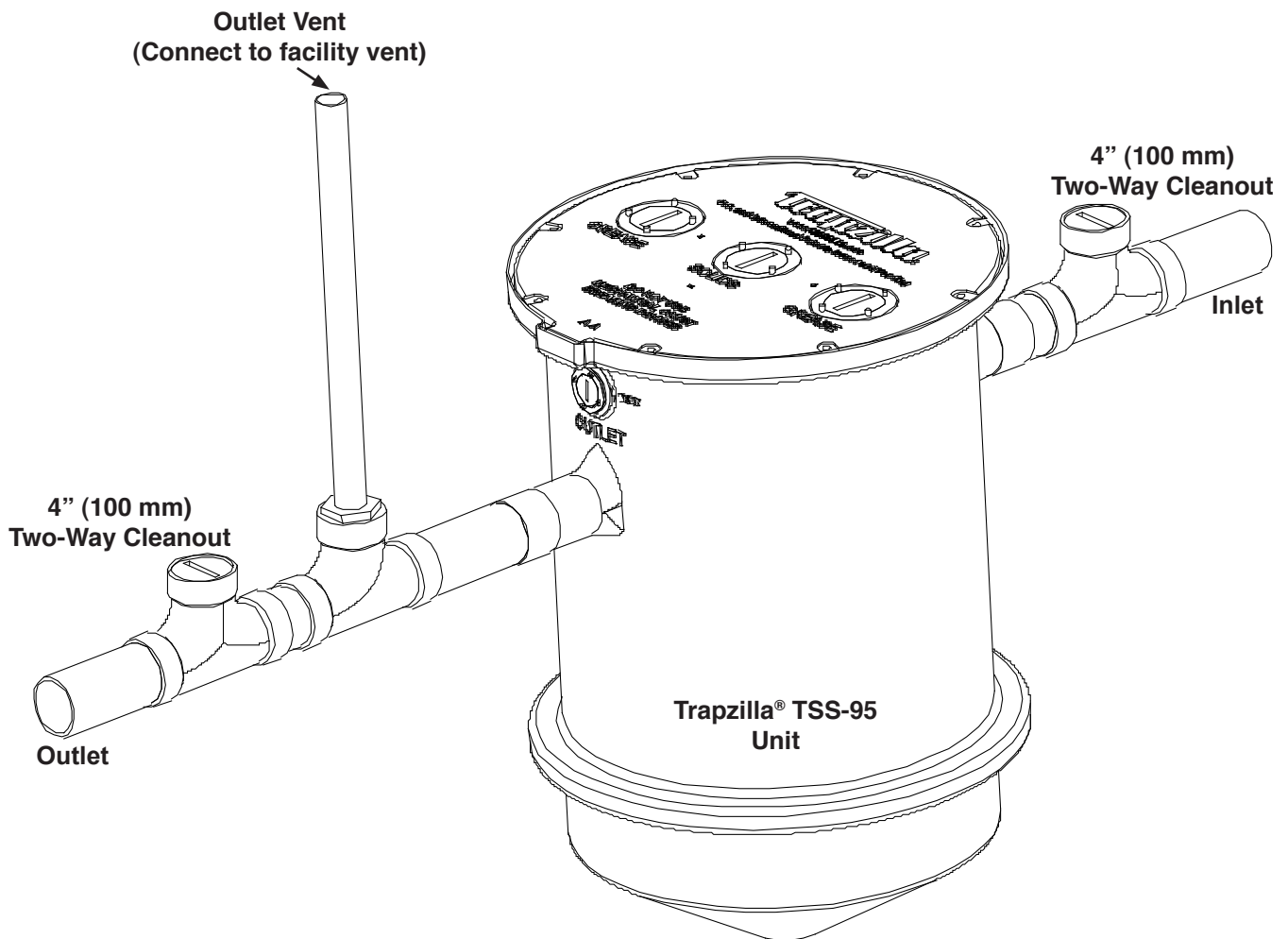

Note: Drawing for reference only. Equipment must be installed in compliance with all applicable laws, regulations and codes, including plumbing codes. Installation should be performed by a qualified plumber.

Trapzilla Solids Separator Maintenance

Periodically, the Trapzilla® Solids Separator will need to be pumped. There are three portals on the lid of the unit; one is labelled “Solids”. To pump out the solids, remove the plug from the “Solids” portal. A pump hose may be inserted into the solids portal - be sure to lower the hose all the way to the bottom of the Trapzilla Solids Separator. Solids may then be pumped from the solids hopper. Upon removal of the solids, replace the plug in the “Solids” portals.

Solids build-up inside the Trapzilla unit may be gauged using a Sludge Judge or similar device.

Note:

1) Do NOT use mechanical crust breaking devices to break down any mat that has formed inside the Trapzilla unit.

2) Remove all three port plugs PRIOR to suction (pumping). Re-install the port plugs when all pumping is complete.

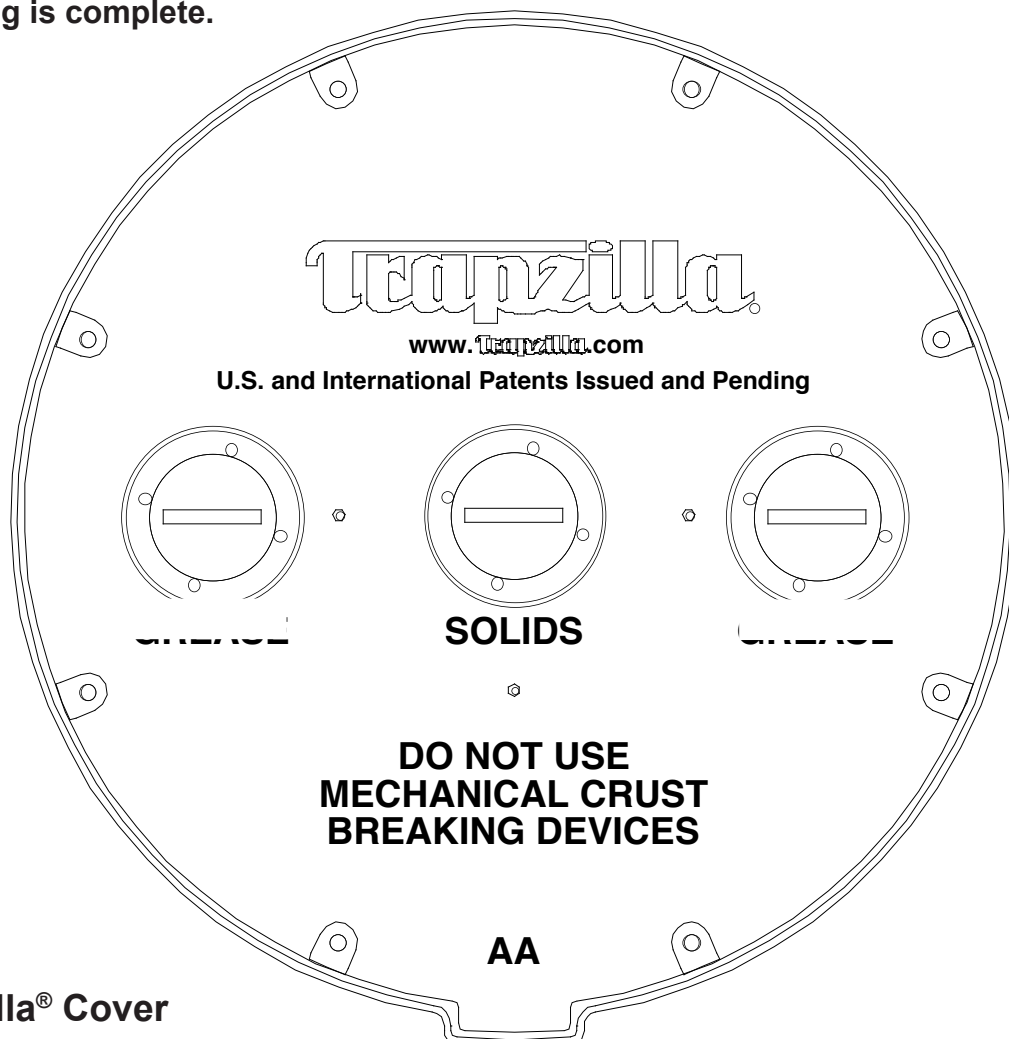

Trapzilla® Cover

Trapzilla System Maintenance

A Jetter Port is located on top of the Outlet Invert to facilitate jetting the Outlet of the Trapzilla. To jet the Outlet Invert, remove the plug from the Jetter Port. After jetting, replace the plug into the Jetter Port.

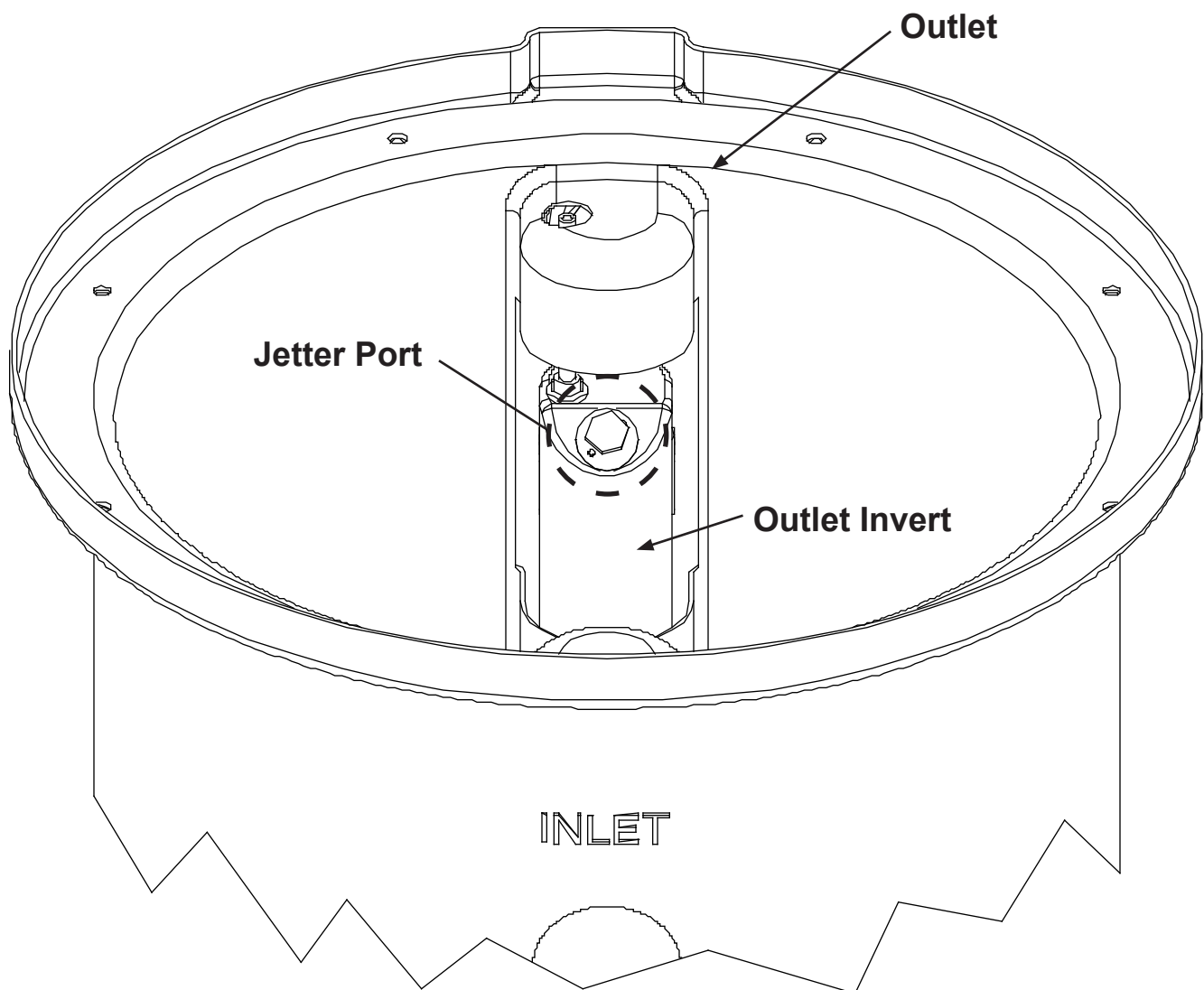



Trapzilla® Solids Separators

Options

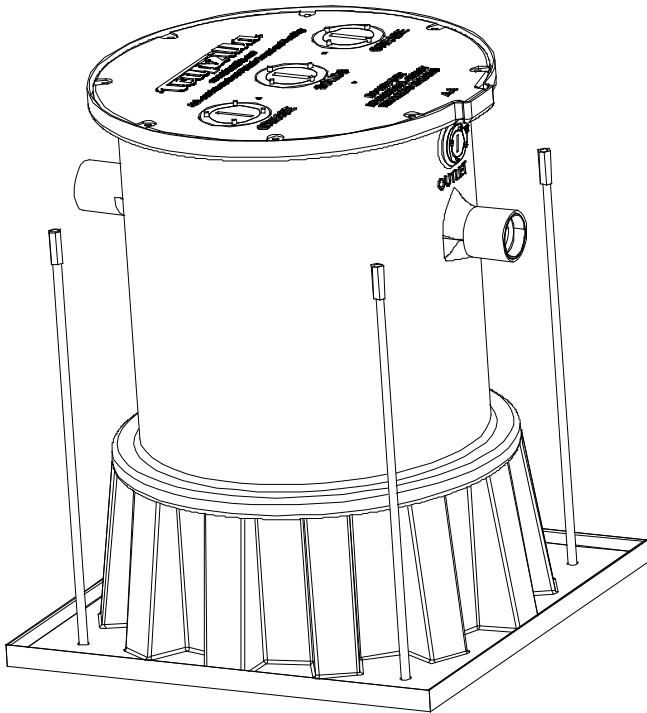

Trapzilla HA-400/600 Hanging Assembly: allows unit to be suspended from the ceiling below the floor.

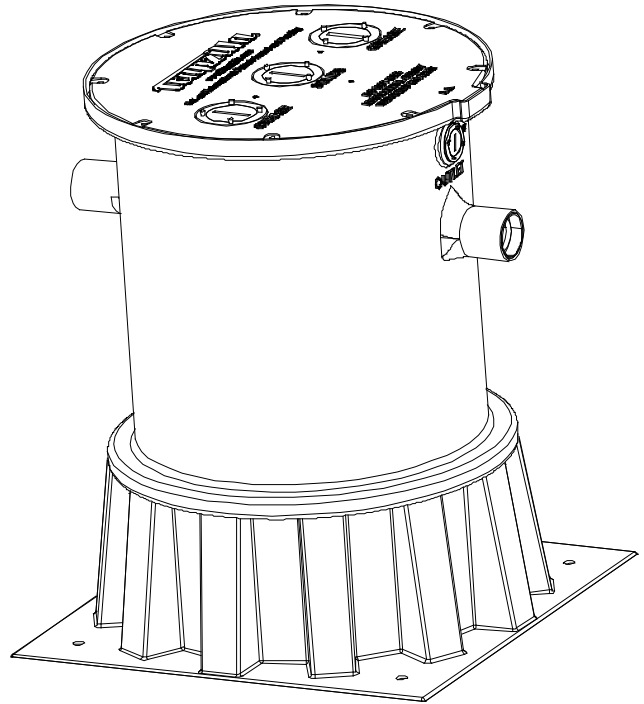

Trapzilla SSA-400/600 Support Stand: allows unit to be installed directly on the floor in a basement or mechanical room.

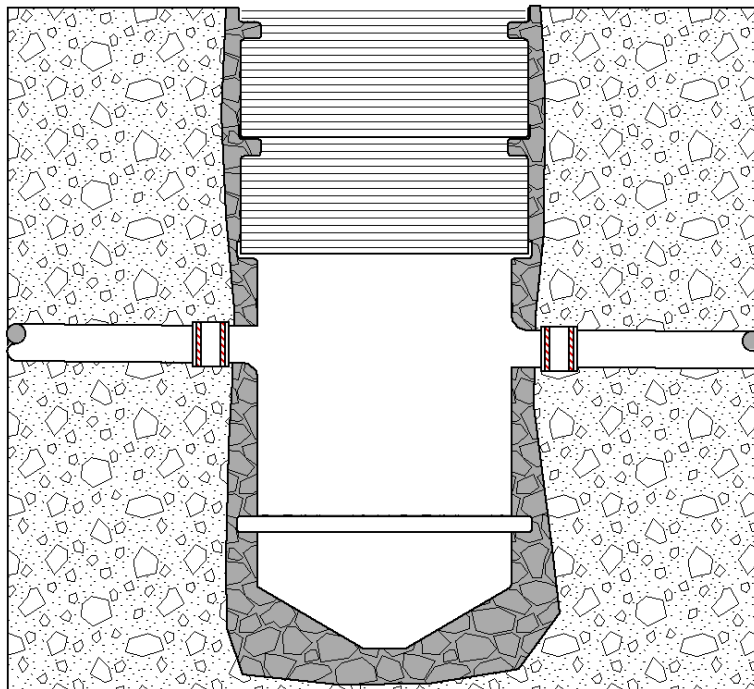

The Trapzilla may also be installed below ground. Shown here using optional ECA-400/600 field-modifiable extension collars to accommodate different kitchen drainage piping depths.

©2008 Thermaco, Inc. All rights reserved • Patented/Patents Pending • Specifications subject to change without notice

Thermaco, Inc. • 646 Greensboro St. • Asheboro, N. C. 27204-2548 • Phone (336) 629-4651

MNL-TSS7095 8



Trappzilla® Solids Separators

In-Ground Installation

A Trappzilla unit may also be installed in the ground outside of the facility. For instances where the facility drainage piping is deep in the ground, the ECA Extension Collar Assembly may be installed to align the Trappzilla inlet with the drainage piping. The ECA may be trimmed in the field to fit. There are trim lines in 1" increments on each ECA to aid in trimming. Thermaco, Inc. also recommends embedding the in-ground Trappzilla with concrete to provide additional structural strength and to off set buoyancy effects. For Buoyancy Calculations & suggested concrete fill quantities please see the following page. Use part number ECA-400/600 for Models TSS-70 & TSS-95.

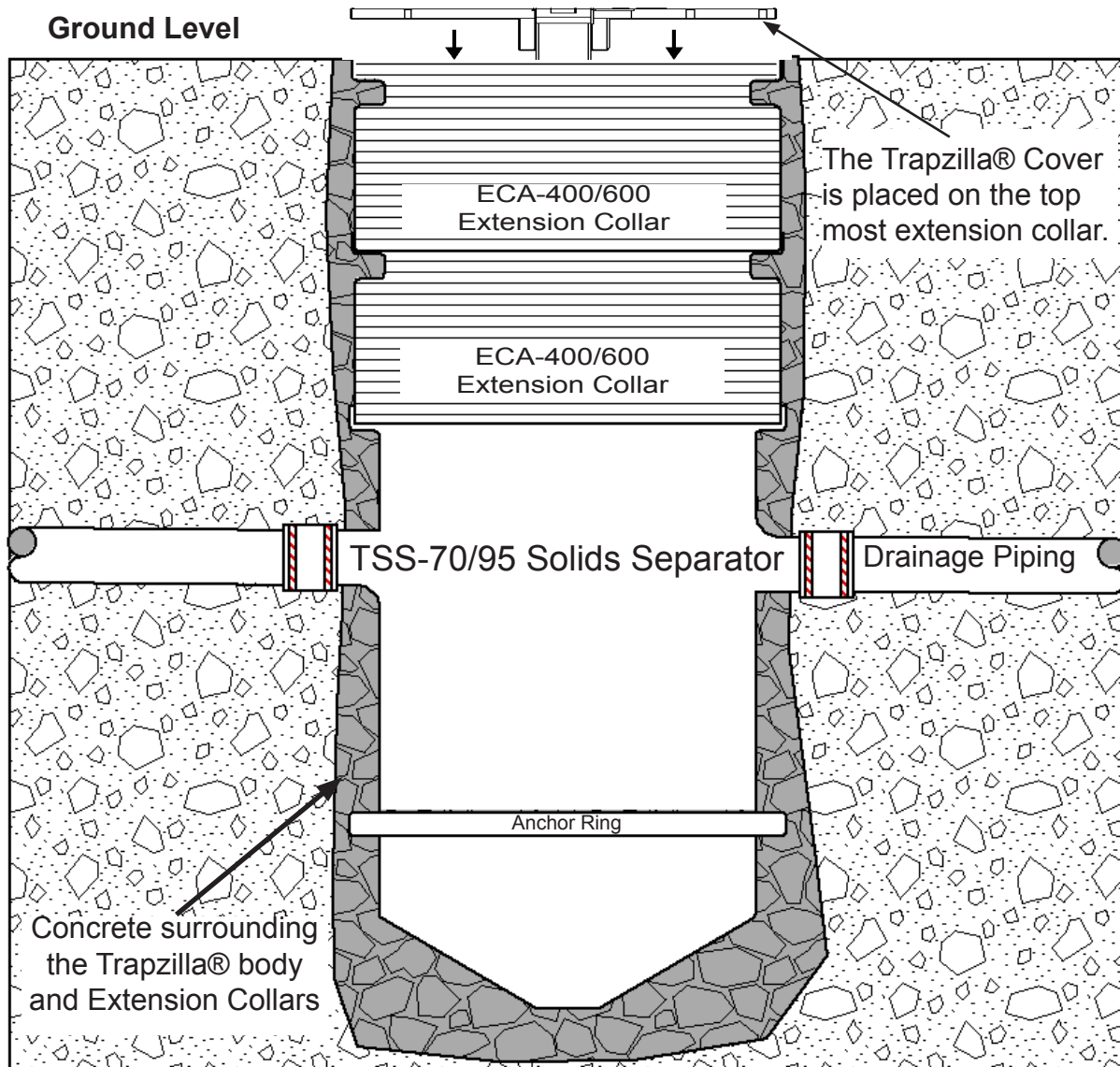

* If the ECA-400/600 Extension Collar is trimmed, Thermaco, Inc. provides screws to attach the Collar to the Trappzilla unit. The screws must be located horizontally through the side of the Collar and Trappzilla Unit. If the Collar is not trimmed, Thermaco, Inc. provides bolts to mount the ECA-400/600 to the Trappzilla unit. The bolts must be placed vertically through the Collar and Trappzilla unit.

©2008 Thermaco, Inc. All rights reserved • Patented/Patents Pending • Specifications subject to change without notice

Thermaco, Inc. • 646 Greensboro St. • Asheboro, N. C. 27204-2548 • Phone (336) 629-4651

MNL-TSS7095 9



Trapzilla® Solids Separators

In-Ground Installation

In order to offset the effects of buoyancy caused by groundwater (high water tables), Thermaco, Inc. recommends concrete be poured around the anchor ring and the Trapzilla® units installed in-ground. The amount of concrete to be used is specified in the table below. The concrete is to be poured continuously and completely surrounding the Trapzilla® body (and Extension Collars if applicable) to ensure proper strength and security.

Buoyancy Calculations TZ Components

CONCRETE

| ITEM | WEIGHT (POUNDS) | VOLUME (CU. YARDS) |
|--------------|-----------------|--------------------|
| TSS-70 | 1525 | 0.40 |
| TSS-95 | 1975 | 0.50 |
| ECA-400/600* | 825 | 0.25 |

* AMOUNT OF CONCRETE TO BE ADDED FOR EACH EXTENSION COLLAR OR PART THEREOF



Trapzilla® Solids Separators Floor Installation

Using the SSA-400/600 Optional Support Stand, a Trapzilla Solids Separator may be installed directly on top of the floor in a location such as a basement or mechanical room.

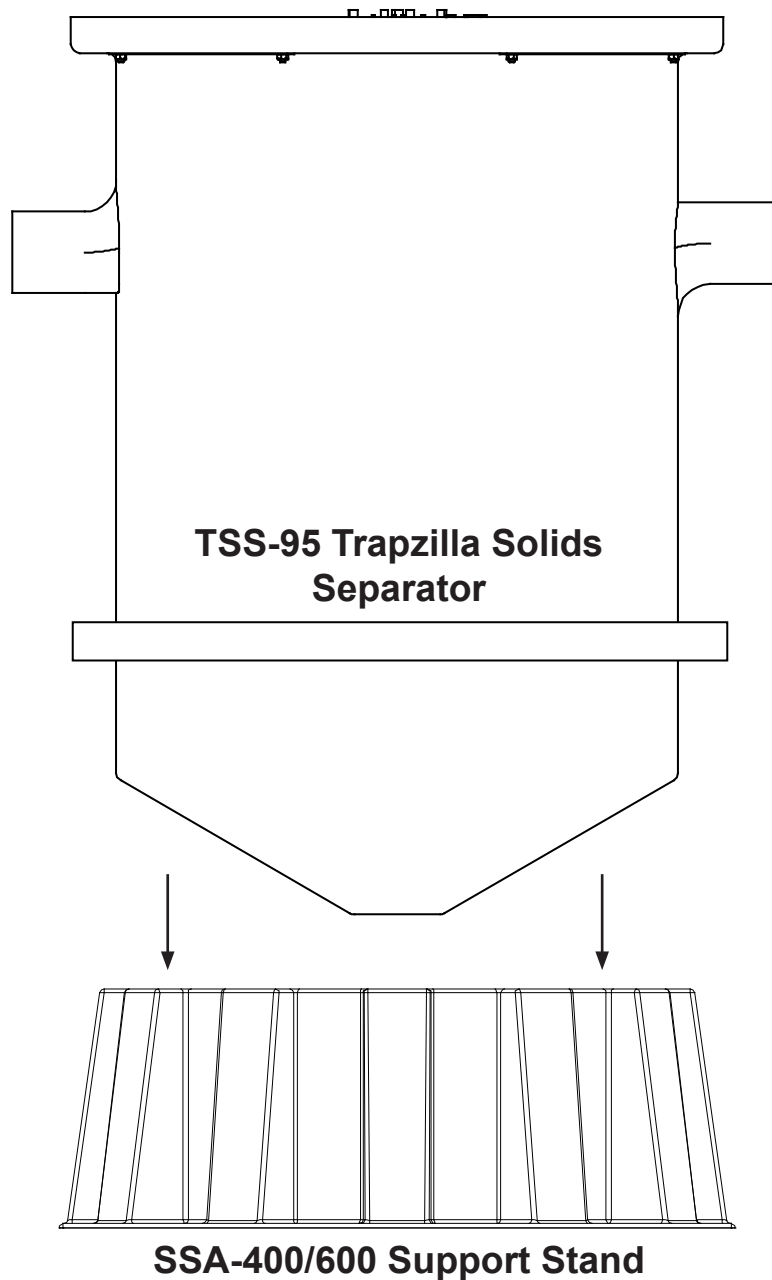

The SSA-400/600 Support Stand is a two-piece construction with a center conical module that sits on the floor. It does not add appreciable height to the assembly.



Trapzilla® Solids Separators

Hanging Installation

Using the HA-400/600 optional Hanging Assembly, a Trapzilla unit may be suspended from a ceiling below the floor of a kitchen or other room.

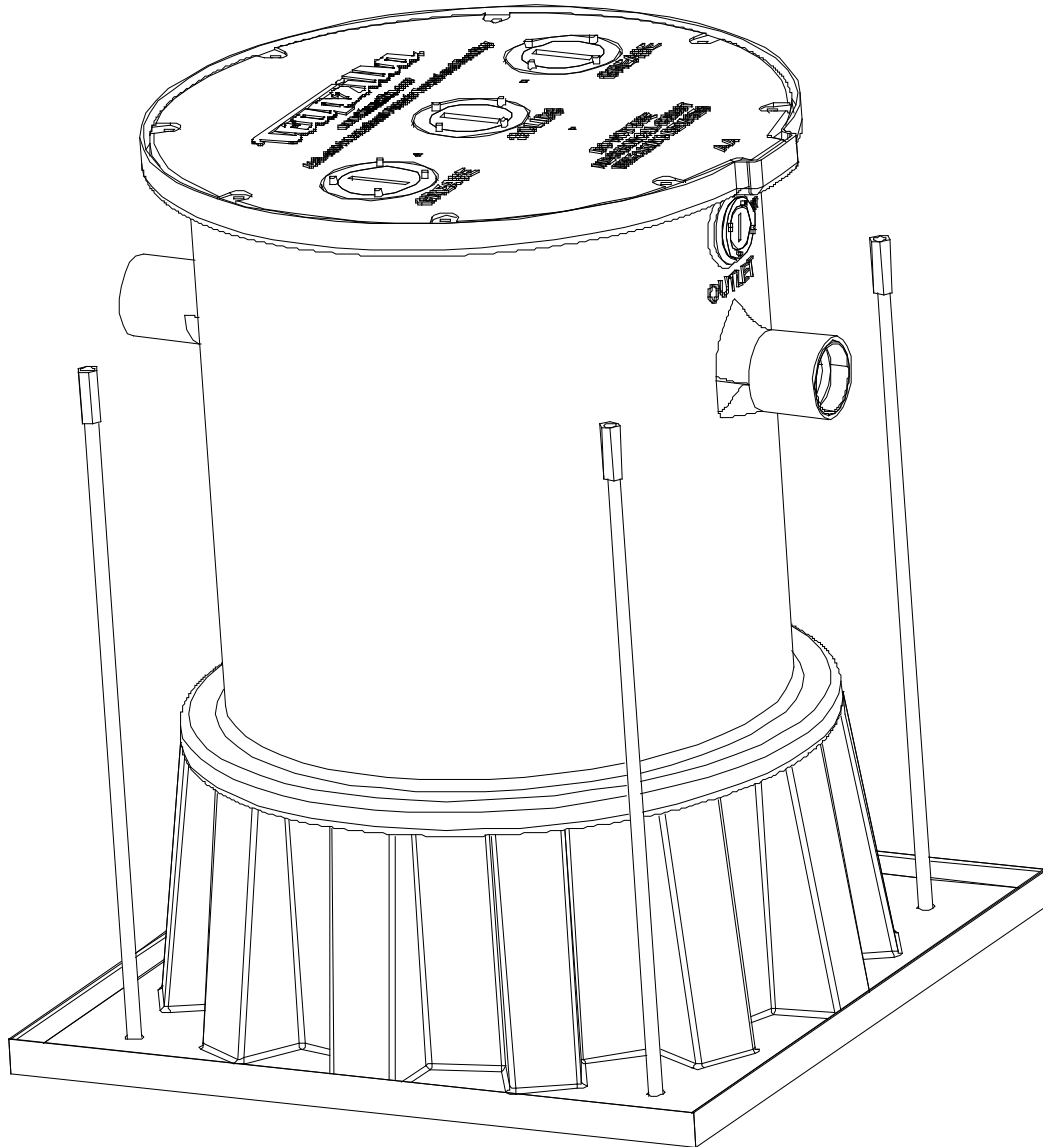

Thermaco, Inc. supplies the frame & support base with the HA-400/600. This kit needs to be installed by a licensed contractor. The contractor is responsible for determining weight loads, preparation of the floor for installation and any construction necessary for installation of the suspension kit.

Note: Drawing for reference only. Equipment must be installed in compliance with all applicable laws, regulations and codes, including plumbing & building codes. Installation should be performed by a qualified plumber and contractor.



Trappzilla® Solids Separators

Limited Warranty & Remedy

Thermaco, Inc. warrants to the original user that the products manufactured by it delivered with this warranty shall be free from material defects in workmanship and materials for a period of 12 months from the date of invoice to the distributor (if sold by an authorized Thermaco distributor) or the date of invoice to the purchaser (if sold directly by Thermaco, Inc.), but in no event longer than 15 months from date of shipment from Thermaco's production facility.

Any claim must be made in writing to Thermaco at 646 Greensboro Street, Asheboro, NC 27203 promptly after discovery of the defect and within the applicable warranty period. The product must be delivered, prepaid, to Thermaco, together with proof of purchase and a return authorization number issued by Thermaco. If Thermaco determines upon examination that the component is defective and that the warranty conditions are met, Thermaco's sole obligation under this warranty, and the purchaser's sole and exclusive remedy, is the repair or replacement, at Thermaco's option, of the defective component, including parts and labor. The replacement will be furnished F.O.B. point of shipment. If Thermaco determines that the component is not defective or that the other conditions of this warranty are not met, then any return of such part to the purchaser shall be at purchaser's cost.

This warranty shall not cover any defect in otherwise covered products resulting directly or indirectly from: (i) failure to properly install, operate or maintain the product in accordance with Thermaco's instructions and procedures, including, without limitation, use in excess of rated flow, use to remove emulsified fats and oils or use that fails to comply with applicable laws, regulations or codes; (ii) damage in transit, handling or installation; (iii) modifications, adjustments, repairs, or alterations made by unauthorized persons; or (iv) other causes not arising out of defects in workmanship or materials. Thermaco shall not be responsible for damage to products resulting from vault flooding, sewer line back-up, pumping or lift station failure, ambient water flow or other sources of water damage. This warranty does not cover equipment or parts not manufactured by Thermaco. Purchaser's costs relating to any service, adjustment, removal, repair, packing, or otherwise incurred with respect to the defect prior to submission for warranty are the responsibility of purchaser.

No distributor, sales person or other person is authorized to make any warranty statements on behalf of Thermaco regarding Thermaco products other than as set forth in this warranty. This statement of warranty supersedes any quote, brochure, or other statement or document with respect to warranty of Thermaco products.

EXCEPT AS EXPRESSLY SET FORTH ABOVE, THERMACO, INC. MAKES NO REPRESENTATIONS, WARRANTIES OR GUARANTEES, EITHER EXPRESSED OR IMPLIED, INCLUDING, WITHOUT LIMITATION, AS TO **MERCHANTABILITY OR FITNESS FOR A PARTICULAR PURPOSE**, WHETHER OR NOT THERMACO HAD KNOWLEDGE OF PURCHASER'S PARTICULAR REQUIREMENTS OR NEEDS, OR WITH RESPECT TO ODOR GENERATION OR OTHER INCIDENTALS RELATING TO USE OF THE PRODUCT.

The sole and exclusive remedy with respect to this warranty any other claim relating to defects or any other condition or use of Thermaco products, however caused, and whether such claim is based upon warranty, contract, tort, strict liability or any other theory, is LIMITED to the repair or replacement of the product, excluding labor or any other cost to remove or install said the product or, at Thermaco's option, repayment of the purchase price. IN NO EVENT SHALL THERMACO, INC. BE LIABLE, WHETHER IN CONTRACT, WARRANTY, TORT (INCLUDING NEGLIGENCE), STRICT LIABILITY, INDEMNITY OR ANY OTHER LEGAL THEORY, FOR INCIDENTAL OR CONSEQUENTIAL DAMAGES, OR FOR ANY OTHER LOSS OR COST OF A SIMILAR TYPE. UNDER NO CIRCUMSTANCES WILL THE AGGREGATE LIABILITY OF THERMACO FOR ANY CAUSE OF ACTION RELATED TO THE PRODUCTS COVERED HEREBY EXCEED THE NET PURCHASE PRICE RECEIVED BY THERMACO FOR THE PRODUCTS. Any action or suit by purchaser against Thermaco relating to Thermaco products must be brought within one (1) year of the date of the invoices referenced above. The exclusions and limitations set forth herein are separate and independent from any remedies which purchaser may have hereunder and shall be given full force and effect whether or not any or all such remedies shall be deemed to have failed of their essential purpose.

©2008 Thermaco, Inc. All rights reserved • Patented/Patents Pending • Specifications subject to change without notice

Thermaco, Inc. • 646 Greensboro St. • Asheboro, N. C. 27204-2548 • Phone (336) 629-4651

MNL-TSS7095 13